



# UPP® SEMI-RIGID PIPEWORK SYSTEM

Since its introduction over forty years ago, as the world's first electrofusion pipework system for fuel applications, UPP® semi-rigid pipework has become known globally as the standard for liquid tight pipework systems. UPP® pipework utilises the advanced electrofusion welding process to effectively bond system components together into one leak proof system.

## HIGHLIGHTS

- UPP® pipe features an innovative clear inner lining made of natural EVOH resin to provide maximum pipe strength and superior vapour permeation and hydrocarbon barrier qualities.
- UPP® pipe is the first to receive an exception Class T1 temperature rating with its EN14125 approval, a true testament to its strength.
- The end of a piping run can be fitted with a wide variety of termination fittings to accommodate any application.
- Fittings are specifically designed to eliminate the number of bolt holes, rubber seals, band clamps and any potential leak paths.
- The UPP® electrofusion welding process is safe and simple to complete in any climate and virtually any weather condition.
- An installer simply prepares the components, fits them together attaching welder leads to the fitting, and then presses a single button on the welding unit to initiate the process.
- The welder unit itself calculates the exact settings required to complete the weld, regardless of the pipework diameter or temperature, leaving no settings for the installer to input.

## Fuel Compatibility

- Motor vehicle fuels typically found in consumer dispensing facilities like gasoline or diesel including blended fuels with maximum 15% MTBE, 15% Methanol or 30% Ethanol.
- Concentrated fuels such as alternate unblended fuels containing up to 100% concentrations of Toluene, Methanol or Ethanol.
- High blend fuels with higher than normal gasoline blends with maximum 50% Methanol or 50% Ethanol.
- Aviation and marine specialty fuels containing up to 100% kerosene or leaded gasoline.
- Biodiesel compatibility:
  - Biodiesel up to 5% (B5)
  - Biodiesel up to 20% (B20)
  - Biodiesel at 97% - 100% (B99 / B100)
  - All ASTM defined biofuel blends



## SPECIFICATIONS

### UPP® EN14125: 2013 Standard Primary Pipe

Material	PE100 with EVOH resin barrier
Primary pressure rating	10/145 (bar/psi)
Primary colour	Black with two clusters of four green stripes, clear inner liner
Temperature rating	Class T1 Rating (EN14125:2013) -40° C to 50° C
Primary vacuum rating	-0.9/-26.6 (-bar/"Hg)

### UPP® EN14125: 2013 Standard Fill Pipe

Material	PE100 with EVOH resin barrier
Primary pressure rating	6/87 (bar/psi)
Primary colour	Black with two clusters of four green stripes, clear inner liner
Temperature rating	Class T1 Rating (EN14125:2013) -40° C to 50° C

### UPP® EN14125: 2013 Standard Coaxial (Secondary) Pipe

Material	PE100 with EVOH resin barrier
Primary pressure rating	10/145 (bar/psi)
Primary colour	Black with four green stripes, clear inner liner
Secondary color	Black with six green stripes, clear inner liner
Primary vacuum rating	5/72 (-bar/"Hg)
Secondary vacuum rating	-0.6/-17.8 (bar/psi)
Temperature rating	Class T1 Rating (EN14125:2013) -40° C to 50° C

### UPP® EN14125: 2013 Standard Secondary Sleeve

Material	PE100
Secondary pressure rating	5/72 (bar/psi)
Primary colour	Black with six green stripes
Temperature rating	Class T1 Rating (EN14125:2013) -40° C to 50° C
Primary vacuum rating	-0.6/17.8 (-bar/"Hg)

## ORDER INFORMATION

### UPP® EN14125:2013 Standard Primary Pipe

Model	Ø (mm)	Unit	SDR	Primary ID (mm)	Bend Radius (m)
001-032-100-E	32	100 m Coil	11	26	0.5
001-050-006-E	50	5.8 m Stick	11	40.8	0.75
001-050-050-E	50	50 m Coil	11	40.8	0.75
001-050-100-E	50	100 m Coil	11	40.8	0.75
001-063-006-E	63	5.8 m Stick	13.6	53.6	0.9
001-063-008-E	63	8 m Stick	13.6	53.6	0.9
001-063-100-E	63	100 m Coil	13.6	53.6	0.9
001-090-006-E	90	5.8 m Stick	13.6	76.6	2.25
001-090-050-E	90	50 m Coil	13.6	76.6	2.25
001-110-006-E	110	5.8 m Stick	13.6	93.8	2.75
001-160-005-E	160	5.8 m Stick	--	--	--
001-160-011-E	160	11.5 m Stick	--	--	--

### UPP® EN14125:2013 Standard Fill Pipe

Model	Ø (mm)	Unit	SDR	Primary ID (mm)	Bend Radius (m)
001-110-006-FILL-E	110	5.8 m Stick	17	96.8	2.75

### UPP® EN14125:2013 Standard Coaxial (Secondary) Pipe

Model	Ø (mm)	Unit	SDR	Primary ID (mm)	Bend Radius (m)
001-040-032-050-E	40/32	50 m Coil	11 / 17	26	0.6
001-040-032-100-E	40/32	100 m Coil	11 / 17	26	0.6
001-063-050-030-E	63/50	30 m Coil	11 / 26	40.8	0.9
001-063-050-100-E	63/50	100 m Coil	11 / 26	40.8	0.9
001-075-063-010-E	75/63	10 m Stick	13.6 / 26	53.6	1.12
001-075-063-030-E	75/63	30 m Coil	13.6 / 26	53.6	1.12
001-075-063-050-E	75/63	50 m Coil	13.6 / 26	53.6	1.12
001-125-110-030-E	125/110	30 m Coil	13.6 / 21	92.6	2.75
001-125-110-050-E	125/110	50 m Coil	13.6 / 21	92.6	2.75

### UPP® EN14125:2013 Standard Secondary Sleeve

Model	Ø (mm)	Unit	SDR	Bend Radius (m)
000-063-006-SC-E	63	5.8 m Stick	26	0.9
000-075-006-SC-E	75	5.8 m Stick	26	1.12
000-075-008-SC-E	75	8 m Stick	26	1.12
000-110-006-SC-E	110	5.8 m Stick	26	2.75
000-125-006-SC-E	125	5.8 m Stick	26	3.1

# PRIMARY PIPING

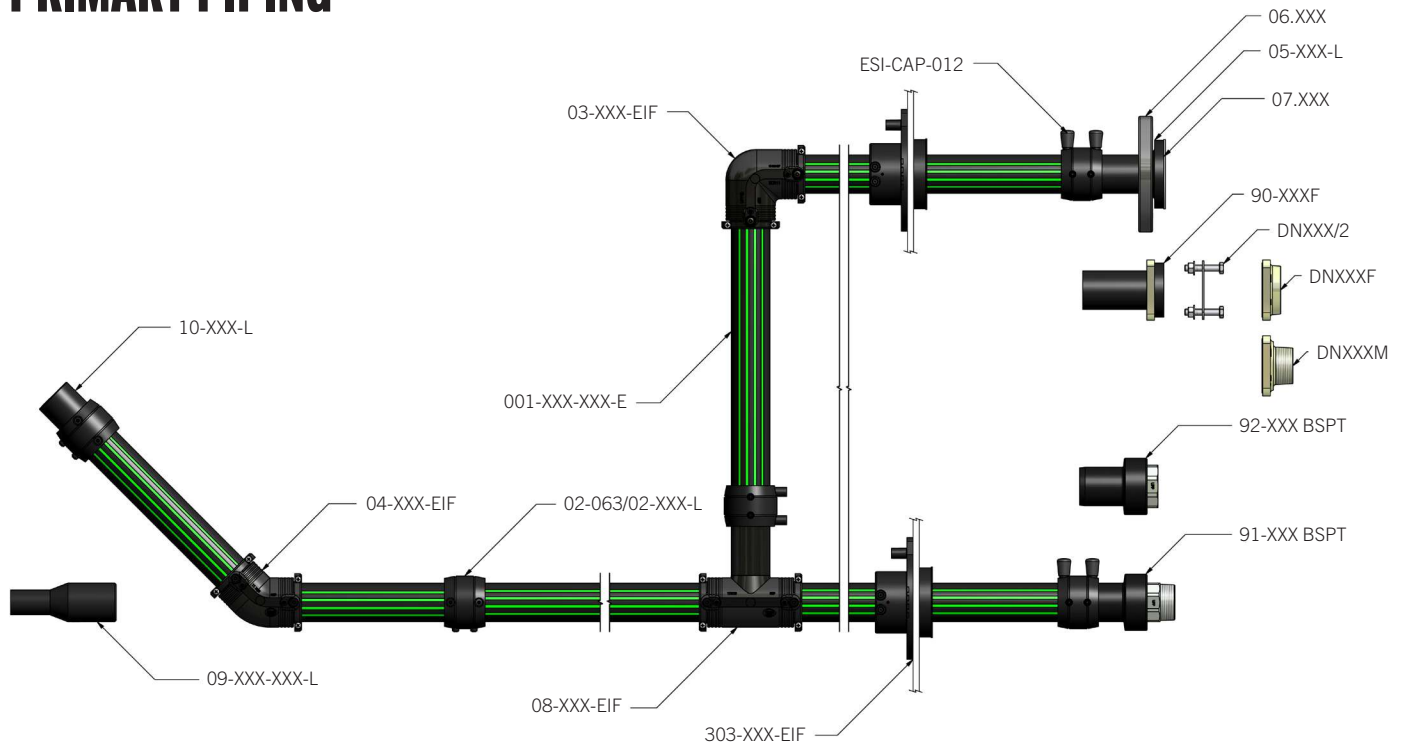

Model	Description	Unit
001-032-100-E	Extra Pipe–32 mm	100 m coil
001-050-006-E	Extra Pipe–50 mm	5.8 m stick
001-050-050-E		50 m coil
001-050-100-E		100 m coil
001-063-006-E	Extra Pipe–63 mm	5.8 m stick
001-063-008-E		8 m stick
001-063-100-E		100 m coil
001-090-006-E	Extra Pipe–90 mm	5.8 m stick
001-090-050-E		50 m coil
001-110-006-E	Extra Pipe–110 mm	5.8 m stick
001-110-006-FILL-E	Extra Pipe FILL–110 mm	5.8 m stick
001-110-050-FILL-E		50 m coil
001-160-011-E	Extra Pipe–160 mm	11.5 m stick



Model	Description	Diameter Ø (mm)
02-032-L	Fusion coupler–long	32
02-050-L	Fusion coupler–long	50
02-063	Fusion coupler–long	63
02-090-L	Fusion coupler–long	90
02-110-L	Fusion coupler–long	110
02-160-L	Fusion coupler–long	160



Model	Description	Diameter Ø(mm)
03-050-L	Plain elbow	50
03-063-L	Plain elbow	63
03-090-L	Plain elbow	90
03-110-L	Plain elbow	110
03-160-L	Plain elbow	160



Model	Description	Diameter Ø(mm)
03-032-EIF	Electrofusion elbow	32
03-050-EIF	Electrofusion elbow	50
03-063-EIF	Electrofusion elbow	63
03-090-EIF	Electrofusion elbow	90
03-110-EIF	Electrofusion elbow	110



Model	Description	Diameter Ø(mm)
04-050-L	Plain elbow	50
04-063-L	Plain elbow	63
04-090-L	Plain elbow	90
04-110-L	Plain elbow	110
04-160-L	Plain elbow	160



Model	Description	Diameter Ø (mm)
04-032-EIF	Electrofusion	32
04-050-EIF	Electrofusion	50
04-063-EIF	Electrofusion	63
04-090-EIF	Electrofusion	90
04-110-EIF	Electrofusion	110



Model	Description	Diameter Ø (mm)
05-032-L	Stub	32
06.32	Flange circular PN DN22	32
07.32	Gasket for stub	32
05-050-A	Stub, ANSI	50
05-050-L	Stub	50
06.50	Flange circular PN16 DN40	50
07.50	Gasket 50 mm for stub	50
05-063-L	Stub 63 mm	63
06.63	Flange circular PN16 DN50 63 mm	63
07.63	Gasket 63 mm for stub	63
05-090-L	Stub 90 mm	90
06.90	Flange circular PN16 DN80 90 mm	90
07.90	Gasket 90 mm for stub	90
05-110-L	Stub 110 mm	110
06.110	Flange circular PN16 DN100 110 mm	110
07.110	Gasket 110 mm for stub	110
05-160-L	Stub 160 mm	160
06.160	Flange circular PN16 DN150 160 mm	150/160
07.160	Gasket 160 mm for stub	160



Model	Description	Diameter Ø (mm)
08.32	Tee equal	32
08-050-L	Tee equal	50
08-063-L	Tee equal	63
08-090-L	Tee equal	90
08-090-063-L	Reducer tee equal	90/63
08-110-L	Tee equal	110
08.110.063-L	Reducer tee equal	110/63
08-160-L	Tee equal	160



Model	Description	Diameter Ø (mm)
08-032-EIF	Electrofusion tee equal	32
08-050-EIF-S	Electrofusion tee equal	50
08-063-EIF-S	Electrofusion tee equal	63
08-090-EIF-S	Electrofusion tee equal	90
08-110-EIF	Electrofusion tee equal	110



Model	Description	Diameter Ø (mm)
09-063-050-EIF	Fusion reducer	63/50
09-090-063-EIF	Fusion reducer	90/63
09-110-090-EIF	Fusion reducer	110/90



Model	Description	Diameter Ø (mm)
09-050-032-L	Plain reducer	50/32
09-063-032-L	Plain reducer	63/32
09-063-050-L	Plain reducer	63/50
09-090-050-L	Plain reducer	90/50
09-090-063-L	Plain reducer	90/63
09-110-063-L	Plain reducer	110/63
09-160-110-L	Plain reducer	160/110



Model	Description	Diameter Ø (mm)
10-032-L	End cap	32
10-050-L	End cap	50
10-063-L	End cap	63
10-090-L	End cap	90
10-110-L	End cap	110



Model	Description	Diameter Ø (mm)
302-040	Fusion seal	40
303-050-EIF	Fusion seal with integrated coupler	50
303-063-EIF	Fusion seal with integrated coupler	63
304-110-090-TP-3	Fusion seal with integrated coupler and test port	90
304-110-EIF	Fusion seal with integrated coupler	110
308	8" Fusion seal for 90/110/160 mm	90/110/160



Model	Description	Diameter Ø (mm)
11.32UF	32 mm x 1" BSP	32



Model	Description	Diameter Ø (mm)
11-503F BSPT	Compression elbow 50 mm x 1½" BSPT female	50



Model	Description	Diameter Ø (mm)
11-508 BSPT	Compression tee 50 mm x 1½" BSP female	50



Model	Description	Diameter Ø (mm)
11.321	32 mm x 1" BSP male	32

11-501M BSPT	Compression termination 50 mm x 1½" BSPT male	50
--------------	---	----

11-631M BSPT	Compression termination 63 mm/2" diameter - BSPT	63
--------------	--	----

11-631M-1 BSPT	Compression termination 63 mm/1½" diameter - BSPT	63
----------------	---	----

12-050 BSPT	Compression termination 50 mm/1½" diameter - BSPT male	50
-------------	--	----

12-063 BSPT	Compression termination 63 mm/2" diameter - BSPT male	63
-------------	---	----

12-063-1 BSPT	Compression termination 50 mm/1½" diameter - BSPT male	63
---------------	--	----

12-090 BSPT	Compression termination 90 mm/3" diameter - BSPT male	90
-------------	---	----

12-110 BSPT	Compression termination 110 mm/4" BSPT diameter - BSPT male	110
-------------	---	-----



Model	Description	Diameter Ø (mm)
91-032 BSPT	Termination 32 mm x 1" BSPT male	32

91-050 BSPT	Termination 50 mm x 1½" BSPT male	50
-------------	-----------------------------------	----

91-050 NPT	Termination 50 mm x 1½" NPT male	50
------------	----------------------------------	----

91-063 BSPT	Termination 63 mm x 2" BSPT male	63
-------------	----------------------------------	----

91-063 NPT	Termination 63 mm x 2" NPT male	63
------------	---------------------------------	----

91-063-1 BSPT	Termination 63 mm x 1½" BSPT male	63
---------------	-----------------------------------	----

91-063-1 NPT	Termination 63 mm x 1½" NPT male	63
--------------	----------------------------------	----

91-090 BSPT	Termination 90 mm x 3" BSPT male	90
-------------	----------------------------------	----

91-090 NPT	Termination 90 mm x 3" NPT male	90
------------	---------------------------------	----

91-110 BSPT	Termination 110 mm x 4" BSPT male	110
-------------	-----------------------------------	-----

91-110 NPT	Termination 110 mm x 4" NPT male	110
------------	----------------------------------	-----

12-XXX



Model	Description	Diameter Ø (mm)
92-032 BSPT	Termination 32 mm x 1" BSPT female	32
92-050 BSPT	Termination 50 mm x 1½" BSPT female	50
92-050 NPT	Termination 50 mm x 1½" NPT female	50
92-050 UF BSPT	Union termination 50 mm x 1½" BSPT female	50
92-050 UF NPT	Union termination 50 mm x 1½" NPT female	50
92-063 BSPT	Termination 63 mm x 2" BSPT female	63
92-063 NPT	Termination 63 mm x 2" NPT female	63
92-063 UF BSPT	Union termination 63 mm x 2" BSPT female	63
92-063-1 BSPT	Termination 63 mm x 1½" BSPT female	63
92-063-1 NPT	Termination 63 mm x 1½" NPT female	63
92-063UF NPT	Union termination 63 mm x 2" NPT female	63
92-090 BSPT	Termination 90 mm x 3" BSPT female	90
92-090 SS BSPT	Stainless steel termination 90 mm x 3" BSPT female	90
92-090 NPT	Termination 90 mm x 3" NPT female	90
92-110 BSPT	Termination 110 mm x 4" BSPT female	110
92-110 NPT	Termination 110bmm x 4" NPT female	110



Model	Description	Diameter Ø (mm)
91-032 SS BSPT	Stainless steel termination 32mm x 1" BSPT male	32
91-050 SS BSPT	Stainless steel termination 50mm x 1½" BSPT male	50
91-063 SS BSPT	Stainless steel termination 63mm x 2" BSPT male	63



Model	Description	Diameter Ø (mm)
92-032 SS BSPP	Stainless steel termination 32 mm x 1" BSPP female	32
92-050 SS BSPP	Stainless steel termination 50 mm x 1½" BSPP female	50
92-063 SS BSPP	Stainless steel termination 63 mm x 2" BSPP female	63



Model	Description	Diameter Ø (mm)
90-050F	Flanged termination 50 mm	50
DN40/2	Gasket & bolt set for coupling flange DN 40	50
DN40F	Coupling flange 50 mm BSPP female	50
DN40M	Coupling flange 50 mm BSPT male	50
90-063F	Flanged termination 63 mm	63
DN50/2	Gasket & bolt set for coupling flange DN 50	63
DN50F	Coupling flange 63 mm BSP female	63
DN50M	Coupling flange 63 mm BSPT male	63
DN50M NPT	Coupling flange 63 mm NPT male	63
90-090F	Flanged termination	90
DN80/2	Gasket & bolt set for coupling flange DN 80	90
DN80F	Coupling flange 90 mm BSP female	90
DN80M	Coupling flange 90 mm BSPT male	90
90-110F	Flanged termination 110 mm	110
DN100/2	Gasket & bolt set for coupling flange DN 100	110
DN100F	Coupling flange 110 mm BSP female	110



Model	Description	Diameter Ø (mm)
BV(2)	Ball valve 63 mm BSP F/F ¼ turn - galvanized steel	63



Model	Description	Diameter Ø (mm)
ESI-CAP-012	Weld pin protection cap	All
91-050-TOOL	Plate spanner 50A/F 91-050 for all male 50 mm sizes	50
92-050-TOOL	Plate spanner 55A/F 92-050 for all female 50 mm sizes	50
11.50G	Spare gasket for 50 UF fittings	50
408046001	O-ring NBR 35 x 2.5 for 12-050	50
91-063-TOOL	Plate spanner 62A/F 91-063 for all male 63 mm sizes	63
92-063-TOOL	Plate spanner 67A/F 92-063 for all male 63 mm sizes	63
11.63G	Spare gasket for 6 UF fittings	63
408045001	O-ring NBR 48 x 3 for 12-063	63
11-63X OL	Spare olive for 11-63X	63
11-50X OL	Spare olive for 11-50X	50
408044001	O-ring NBR 69.5 x 3 for 12-090	90
CW-125-PIPE	Chain wrench 125 mm pipe Mmax	90
408043001	O-ring NBR 89.5 x 3 for 12-110	110

O-Ring



Gasket



Weld Cap



Olive



Male Spanner



Female Spanner



# SECONDARY PIPING

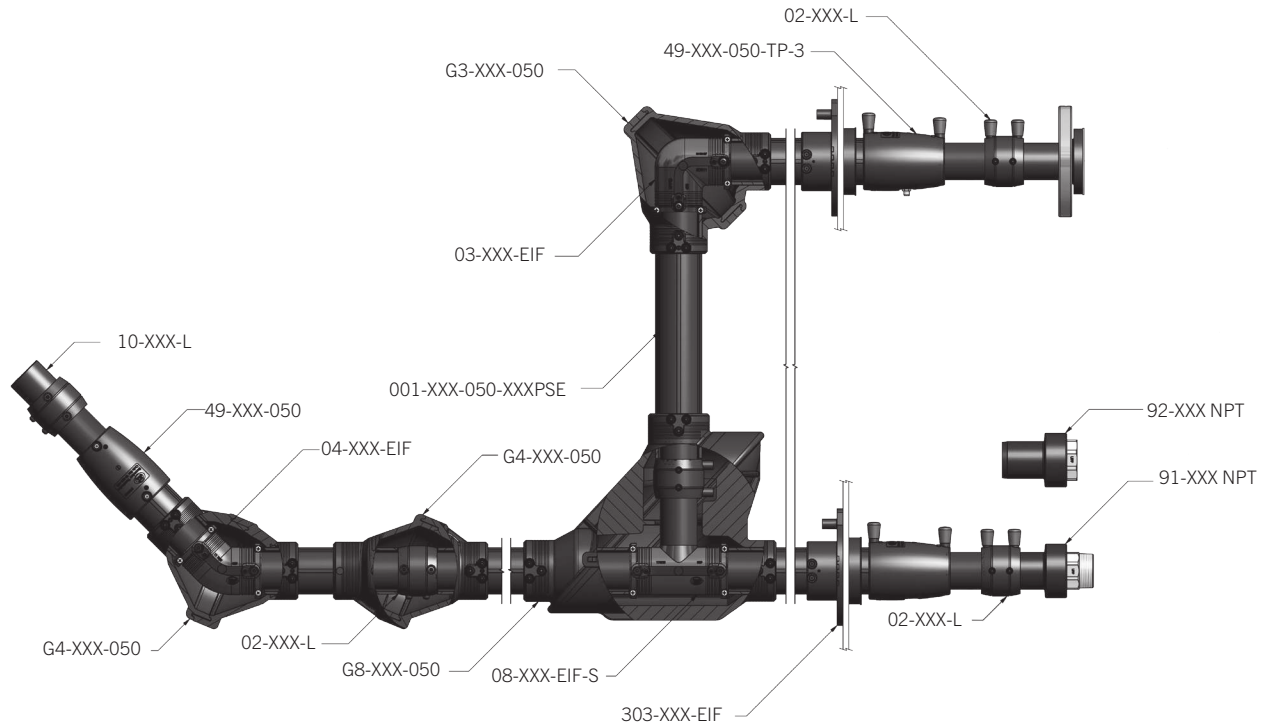

Model	Description	Pack Size	Diameter Ø (mm)
001-040-032-050-E	Extra coaxial pipe	50 m coil	40/32
001-040-032-100-E	Extra coaxial pipe	100 m coil	40/32
001-063-050-030-E	Extra coaxial pipe	30 m coil	63/50
001-063-050-100-E	Extra coaxial pipe	100 m coil	63/50
001-075-063-010-E	Extra coaxial pipe	10 m stick	75/63
001-075-063-030-E	Extra coaxial pipe	30 m coil	75/63
001-075-063-050-E	Extra coaxial pipe	50 m coil	75/63
001-125-110-030-E	Extra coaxial pipe	30 m coil	125/110
001-125-110-050-E	Extra coaxial pipe	50 m coil	125/110
000-063-006-SC-E	Secondary pipe	5.8 m stick	63
000-075-006-SC-E	Secondary pipe	5.8 m stick	75
000-075-008-SC-E	Secondary pipe	8 m stick	75
000-110-006-SC-E	Secondary pipe	5.8 m stick	110
000-125-006-SC-E	Secondary pipe	5.8 m stick	125



Model	Description	Diameter Ø (mm)
02.40(SC)	Fusion coupler secondary	40
02.63(SC)	Fusion coupler secondary	63
02.75(SC)	Fusion coupler secondary	75
02.110(SC)	Fusion coupler secondary	110
02.125(SC)	Fusion coupler secondary	125
02.160(SC)	Fusion coupler secondary	160



Model	Description	Diameter Ø (mm)
09.110.75(SC)	Reducer secondary	110/75
09.160.125(SC)	Reducer secondary	160/125
13.75.40(SC)	Reducer secondary	75/40



Model	Description	Diameter Ø (mm)
302-040	Fusion seal 40 mm	40
303-063-EIF	Fusion seal 63 mm with integrated coupler	63
303-075-EIF	Fusion seal 75 mm with integrated coupler	75
303-075-EIF-2	Fusion seal 75 mm with integrated coupler, 4 mm weld pins	75
304-110-050-TP-3	Fusion entry seal with secondary coupler 110 x 50 mm with test port	50
304-110-063-TP-3	Fusion entry seal with secondary coupler 110 x 63 mm with test port	63
304-110-075-TP-3	Fusion entry seal with secondary coupler 110 x 75 mm with test port	75
304-110-090	Fusion seal with 110 & 90 mm coupler	90
304-110-090-TP-3	Fusion seal with 110 & 90 mm coupler with test port	90
304-110-EIF	Fusion seal 110 mm with integrated coupler	110
305-125-110	Fusion seal with 125 & 110 mm coupler	110
305-125-110-TP-3	Fusion seal 125 & 110 mm coupler with test port	110
305-125-EIF	Fusion seal 125 mm with integrated coupler	125



Model	Description	Diameter Ø (mm)
49-040-032	Fusion reducer secondary	40/32
49-040-032-TP-3	Fusion reducer secondary with test port	40/32
49-063-050	Fusion reducer secondary	63/50
49-063-050-TP-3	Fusion reducer secondary with test port	63/50
49-075-063-1	Fusion reducer secondary	75/63
49-075-063-TP-3	Fusion reducer secondary with test port	75/63
49-110-063(SC)	Sliding reducer secondary	110/63
49-110-075(SC)	Sliding reducer secondary	110/75
49-110-090	SC welding reducer	110/90
49-110-090-TP-3	SC welding reducer with test port	110/90
49-125-110	SC welding reducer	125/110
49-125-110-TP-3	SC welding reducer with test port	125/110



Model	Description	Diameter Ø (mm)
91-063-050 BSPT	Male, BSPT thread	63/50
91-063-050-TP BSPT	Male, BSPT thread, with test port	63/50
91-075-063-1-TP BSPT	Male, 1½" BSPT thread with test port	75/63
91-075-063-TP BSPT	Male, 2" BSPT thread, with test port	75/63
91-110-090-TP BSPT	Male, BSPT thread, with test port	110/90
91-125-110-TP BSPT	Male, BSPT thread, with test port	125/110



Model	Description	Diameter Ø (mm)
92-063-050 BSPT	Female, BSPT thread	63/50
92-063-050-TP BSPT	Female, BSPT thread, with test port	63/50
92-075-063-1 BSPT	Female, 1½" BSPT thread	75/63
92-075-063-TP BSPT	Female, 2" BSPT thread, with test port	75/63
92-110-090 BSPT	Female, BSPT thread	110/90
92-110-090-TP BSPT	Female, BSPT thread, with test port	110/90
92-125-110 BSPT	Female, BSPT Thread	125/110
92-125-110-TP BSPT	Female, BSPT thread, with test port	125/110



Model	Description	Diameter Ø (mm)
G3-040-032	SC Gemini® 90° elbow	40
G3-063-050	SC Gemini® 90° elbow	63
G3-075-063	SC Gemini® 90° elbow	75
G3-110-090	SC Gemini® 90° elbow	110
G3-125-110	SC Gemini® 90° elbow	125



Model	Description	Diameter Ø (mm)
G4-040-032	SC Gemini® elbow or SC Gemini® inline joint	40/32
G4-063-050	SC Gemini® elbow or SC Gemini® inline joint	63/50
G4-075-063	SC Gemini® elbow or SC Gemini® inline	75/63
G4-110-090	SC Gemini® elbow or SC Gemini® inline joint	110/90
G4-125-110	SC Gemini® elbow or SC Gemini® inline joint	125/90



Model	Description	Diameter Ø (mm)
G8-040-032	SC Gemini® tee	40
G8-063-050	SC Gemini® tee	63
G8-075-063	SC Gemini® tee	75
G8-110-090	SC Gemini® tee	110



Model	Description	Diameter Ø (mm)
10-040-SC	End cap 40 mm secondary	40
10-075-SC	End cap 75 mm secondary	75
10.110(SC)	End cap 110 mm secondary	110



Model	Description
LDT 60-1	Leak detection tube kit - not for use with STB-100 product offering
LDT60-2	Leak detection tube kit - not for use with STB-100 product offering, tube only, no fittings
BPT-200	Leak detection tube kit - for use with STB-100 product offering



Model	Description
ESI-CAP-012	Weld pin protection cap



# UPP<sup>®</sup> ELECTROFUSION PIPEWORK

## FUEL/CHEMICAL COMPATIBILITY CHART TO EN14125:2013 (RETAIL SPECIFIC)

### Automotive Fuels

- Gasohol (E1 to E10)
- Premium Unleaded Gasoline
- Regular Unleaded Gasoline
- Premium Leaded Gasoline
- Diesel

### Bio-Fuels & Blends

- Ethanol 100% (Ethyl alcohol)
- E85 - Ethanol 85% + Unleaded Fuel 15%
- E70 - Ethanol 70% + Unleaded Fuel C 30%
- Ethanol 50% + reference Fuel C 50%
- Ethanol 30% + reference Fuel C 70%
- Ethanol 10% + reference Fuel C 90%
- Biodiesel 10% to 100%

### Methanol Mixtures

- Methanol 100%
- Methanol 50% + Reference Fuel C 50%
- Methanol 15% + Reference Fuel C 85%

### Test Fuels & Fuel Additives

- UL971 – MV, CT, HB, AM
- ASTM Fuel C 100%
- EN14125:2013 Fuel 1
- EN14125:2013 Fuel 2
- No.2 Fuel Oil
- MTBE 10% + reference Fuel C 90%
- MTBE 15% + reference Fuel C 85%
- Toluene
- AdBlue\*

\* Requires stainless steel transition fittings.

### Aviation & Marine Fuels

- Jet A1 (Avtur)
- JP8 (F-34)
- Methmix
- Avgas
- Kerosene

## TRENCHES (WIDTH, DEPTH & FALL BACK)

It is important to construct proper trenches before laying UPP<sup>®</sup> pipe. Trenches should be wide and deep enough to comfortably allow pipe runs, recommended spacing, and backfill materials.

Recommended burial depth of UPP<sup>®</sup> pipe is a minimum of 300 mm (12").

All trenches should be sloped back towards the storage tanks with a recommended gradient of 1:100.

Vapour return lines must have a slope of 1:50 (1/4" per foot) and never less than 1:100 (1/8" per ft) back towards the tank farm, unless in-line joints such as elbows are to be used.

Trench corners should contain a radius suitable for the pipe work.

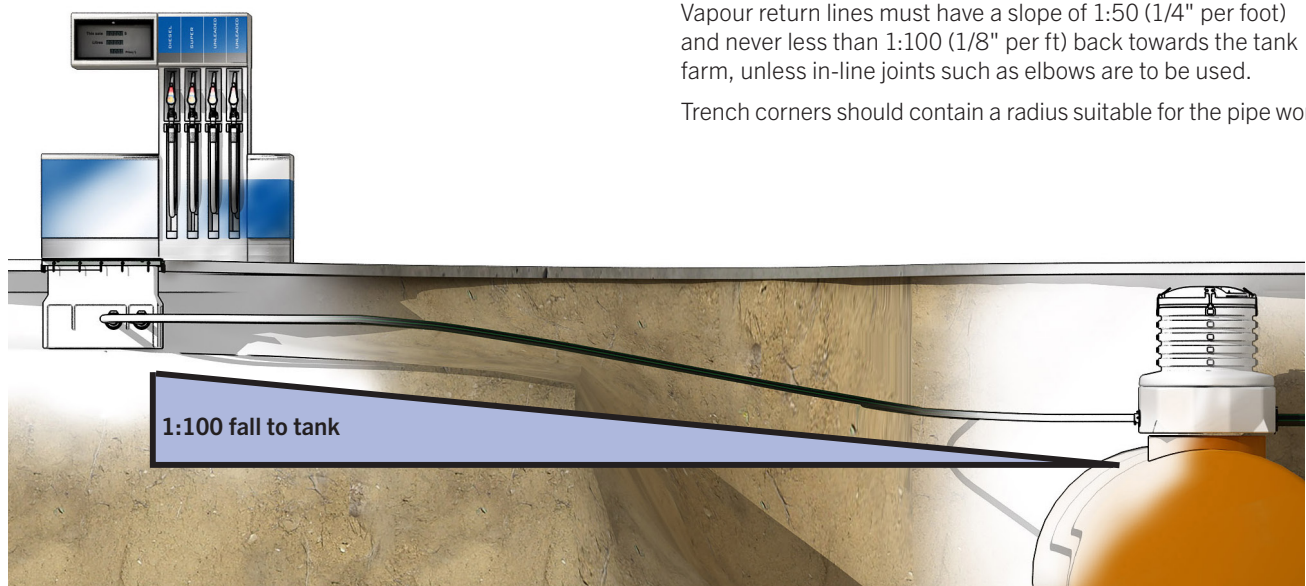

# BEDDING

- A recommended 150 mm (6") bed of backfill material should be laid underneath the prior to pipe installation and there must never be voids under or around the pipe.
- When laying duct onto a concrete base a 150 mm (6") thick bed of compacted sand should be laid on the concrete, below the duct. (Absolute minimum amount of sand should be 50 mm (2") of compacted sand).
- All beds should be laid so that the pipe will not dip or sag when it is installed.
- Underground pipe runs may be continuous or have electrofusion welded joints. Any mechanical joints or compression fittings must be inspectionable and located within a containment chamber or sump.
- UPP® pipe exceeding 12 m (40 ft) should be laid in a series of large snake-like curves and not in straight lines. Uncoiled pipe, when laid, will settle in a natural curve.
- Generally any thermal expansion will be accounted for by following our guidelines for spacing, backfilling and ensuring runs are not dead straight.
- Pipes should be separated from each other by at least the diameter of the largest pipe.
- If pipe-runs cross each other they must be separated by at least as much backfill material as the diameter of the largest pipe or protected by using at least 25 mm (1") of styrofoam.
- If used above ground, UPP® pipe should be protected against mechanical, climatic and fire damage by wrapping it in radiation or thermal shielding tape. Additional supports and anchor points may also be required.
- Contact Franklin Fueling Systems Technical Services for more details concerning above ground installations (see page 86).

# PIPE SPACING

- Bed/backfill with pea-shingle, sand or crushed rock.
- Separate pipes by the diameter of the largest pipe in the run.
- For spacers and support use:
  - Expanded polystyrene (Styrofoam).
  - Pipe off-cuts.
  - Timber/block/brick (as temporary measures).

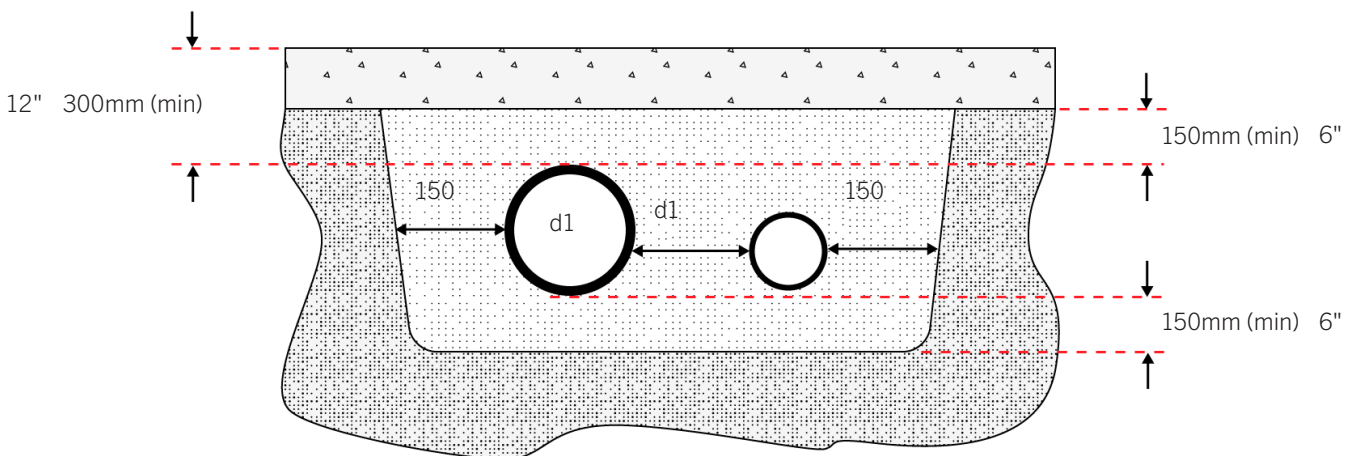

# PRESSURE/VACUUM RATING

The values listed below have been qualified by third party approvals testing.

UPP® Extra & EN14125:2013 Pipes	Rated Pressure		Rated Vacuum		Typical Burst Pressure	
	Bar	Psi	Bar	"Hg	Bar	Psi
Primary Pipe	10	145	-0.9	-26.6	40	580
Secondary Pipe	5	58	-0.6	-17.7	20	290
Fill Pipe	6	87	n/a	n/a	30	435
Electrical Conduit	10	145	-0.9	-26.6	40	580
Corrugated Duct	n/a					

UL971 Pipes						
Primary Pipe	6.2	90	-0.9	-26.6	40	580
Un-Lined Vent Pipe	4	58	-0.6	-17.7	20	290

## BEND RADIUS

Q: Because UPP® is semi-rigid, what bend radius is possible during installation?

A: This is largely temperature dependent, but in general you may use these values for single or double wall UPP® delivered as coils:

		50 mm	63 mm	90 mm	110 mm
Warm Weather	15 x Ø	80 cm	1 m	1.5 m	3 m
Cold Weather	25 x Ø	140 cm	1.6 m	2.5 m	4 m
Very Cold Weather	35 x Ø	190 cm	2.2 m	3.5 m	5 m

For UPP® in 5.8 m straight lengths welded together and then curved to suit the required layout you can expect:

		50 mm	63 mm	90 mm	110 mm
Warm Weather	30 x Ø	1.5 m	2 m	3 m	4 m
Cold Weather	60 x Ø	3 m	3 m	5 m	6 m
Very Cold Weather	80 x Ø	4 m	4 m	7 m	8 m

## INTERSTITIAL VOLUME

When using leak detection equipment it is often necessary to know the interstitial volume of double wall pipes to decide the amount of compressed gas or type of pumped detection unit required. Below are the volumes per metre of UPP® pipework.

Double Wall Pipe							
Interstitial Volume	40/32 mm	63/50 mm	75/63 mm	110/90 mm	125/110 mm	160/90 mm	160/110 mm
	(1")	(1½")	(2")	(3")	(4")	(3")	(4")
Litres / m	0.24	0.66	0.62	2.15	0.97	10.79	7.64
Cubic Inches / ft	4.40	12.29	11.52	39.93	18.01	200.73	142.12

UL971 Double Wall Pipe				
Interstitial Volume	63/50 mm	75/63 mm	110/90 mm	125/110 mm
	(1½")	(2")	(3")	(4")
Litres / m	0.12	0.13	1.41	0.45
Cubic Inches / ft	2.25	2.43	26.21	8.35

# ELECTROFUSION SAFETY

- UPP® welding units must never be operated in Zone 1 or Zone 0 areas (Hazardous area definitions are from IP Model Code of Safe Practice Part 15 and are available in the APEA Blue Book 2nd Edition).
- UPP® welding units are suitable for use in Zone 2 areas with just the welding leads and fitting being welded positioned in a Zone 1 area.
- Ensure welding units are connected to a power supply that meets the requirements detailed in the user manual and are within the requirements of any local authority or regional legislation.
- UPP® piping complies with all the requirements imposed by EN14125:2013 concerning electrostatic safety.
- The risk assessment against electrostatic hazard has demonstrated that the use of insulating material such as that used in UPP® piping results in a safe choice.
- The safety of UPP® systems rely upon the small capacitance and hence the small energy that they can accumulate. This energy, has been demonstrated to be well below the Minimum Ignition Energy or MIE required to ignite petrol or alcohol blended fuel.
- Extensive studies simulating fuel flow situations much more severe than what can be found in underground pipework at petrol filling stations have demonstrated that UPP® pipe cannot be a source of spark ignition. For this reason UPP® pipe can be considered an inherently safe system with respect to the electrostatic risk.
- The most important recommendation, common to any type of piping system is to connect safely to ground all metallic components. Metallic components, and more general conductive materials, thanks to their high capacitance can have the potential to store high amount of electrostatic energy (sparks discharge can only be observed over conductive elements).
- All exposed metal parts used in UPP® System installations should be adequately grounded to a dedicated earth electrode and brought to a potential equal to that of other metal parts in the close proximity.

All UPP® metal transition fittings in the fill box, at the tank top and under the dispenser should be adequately earthed according to local electrical regulations. If in doubt the resistance of grounding should be  $\geq 100k\Omega \leq 1M\Omega$ . Earthing cables should be plastic covered copper conductors of at least  $4mm^2$  cross sectional area and should be connected to an exclusive earth electrode.

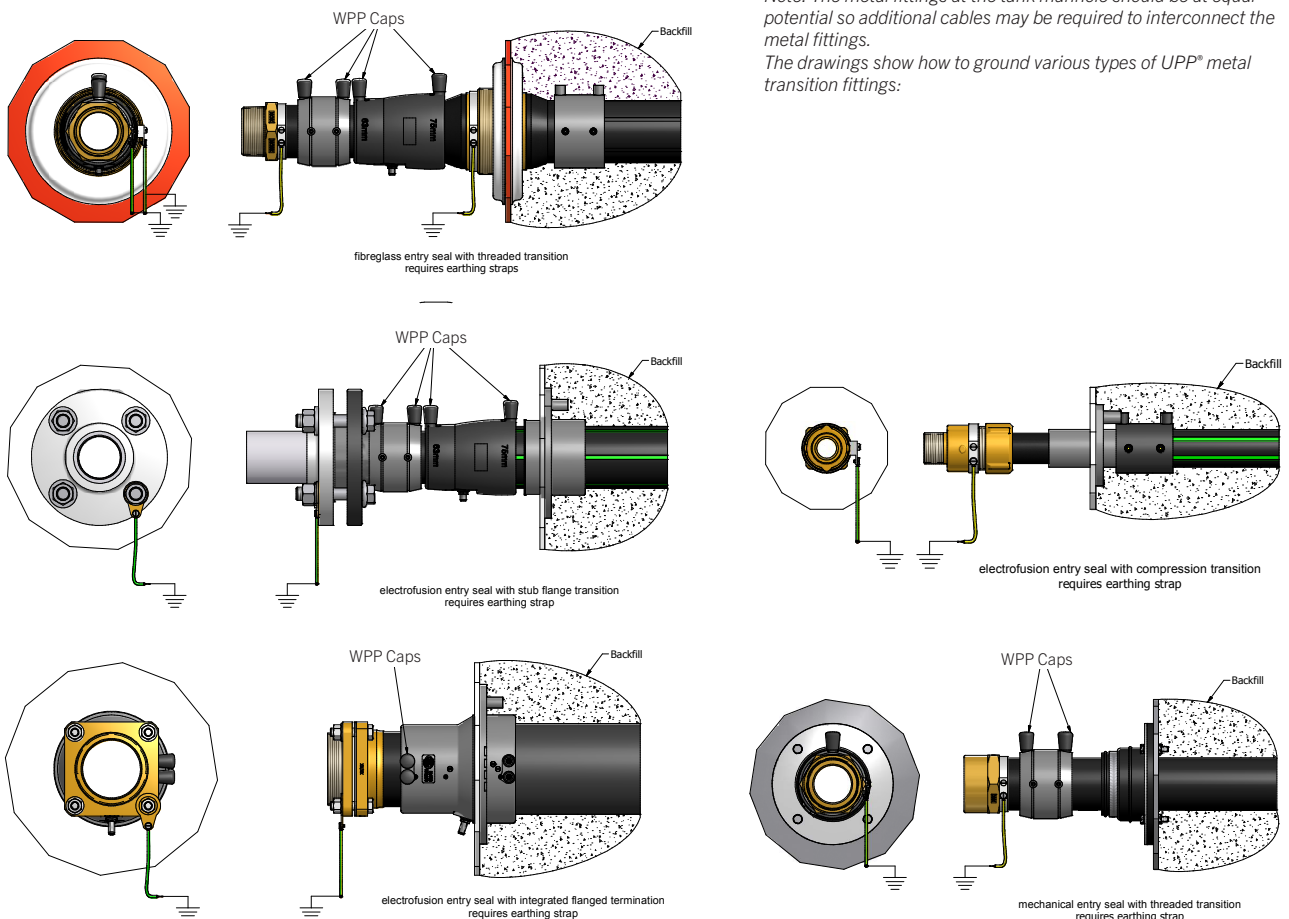

# WELD PIN PROTECTION CAPS

Paragraph 5.6.2 of EN 14125:2004 requires that the terminal pins of electrofusion couplers which are not buried in the ground shall be closed with plastic caps. The purpose is to prevent any perceived risk of ignition hazard resulting from a static electricity discharge in accordance with EN 14125:2004.

Franklin Fueling Systems Ltd has designed a multi-purpose cap to suit all electrofusion fittings in the UPP® System range. The design and materials have been third-party tested and certified as fit-for-purpose.

The caps are only required to be fitted when the coupler is in air (not buried) and when an explosive atmosphere is or may be present, i.e. inside chambers & sumps which are classified as Zone 0, 1 or 2.

- Refer to IP 15–IP Model Code of Safe Practice Part 15 Area classification code for installations handling flammable fluids, 2nd edition - for a definition of these hazardous areas.

Weld Pin Protection Caps are compatible with all UPP® fusion elements such as those for primary and secondary pipework and electro-fusion entry seals. The UPP® System weld pin protection caps have the same fuel resistance as UPP® containment products in which they are designed to be used.

1. Caps should be fitted AFTER tightness testing is completed.
2. Press one cap firmly over each shroud surrounding the pin.
3. Tap cap with light hammer to ensure it is fully seated.
4. Inspect all of the chamber / sump area to ensure that all unburied electro-fusion fittings have been securely fitted with weld pin protection caps.

